



- BENEFITS**
- Table top machine
  - Easy to operate
  - Easy to clean
  - Low maintenance
  - HACCP



**TARTLET**

Produce the finest tart shells with the TARTLET SATELLITE by BAKON USA

- ▶ TRAINING & CLASSES
- ▶ PRODUCT TESTING
- ▶ EQUIPMENT LEASING & FINANCING



Through energy-saving measures, such as dimensioning of electrical power and – where possible – use of recyclable materials, BAKON commits to dealing responsibly with the environment.



The TARTLET SATELLITE makes it easy to create sweet and savory tart shells that are much fresher, cheaper and with higher quality than the pre-baked shells you buy.

Bake the finest tart shells and enjoy fresh, beautiful coloured and shaped tart shells.

This digitally programmable automatic tart shell system makes the difference.



BAKON USA FOOD EQUIPMENT  
20906 Higgins Ct.  
Torrance, CA 90501  
Tel: 1 (310) 533-3939  
Fax: 1 (310) 533-3940  
www.bakonusa.com



BAKON USA designs and produces standardized and customized depositing, spraying and cutting machines as well as production lines for efficient, high-volume processing of pastry products. BAKON USA stands for advanced technology and reliability.



After a warm up time of 15 minutes, it takes less than 10 minutes to shape and bake your tart shells. With a choice of 10 baking moulds it is possible to produce almost any shape or size. An additional feature of the Tartlet Satellite allows you to create sweet and savoury tart shells with an assortment of fillings to finish in the oven or freeze for later use.



The TARTLET SATELLITE is a table top stand-alone machine.



- Ready within 15 minutes (from 0 - 230 °C)
- Adjustable temperature for top and bottom plate
- Baking time is less than 10 minutes
- Teflon coated interchangeable baking moulds
- Up to 45 programmable products



Almost any type of dough



Available teflon coated baking moulds:

T5	ø 12.5 cm, 5 moulds	390 x 340 x 60 mm
T9	ø 9,0 cm, 9 moulds	390 x 340 x 60 mm
T12 waffles	ø 9.9 x 6.5 cm, 12 moulds	390 x 340 x 60 mm
T13	ø 8.0 cm, 13 moulds	390 x 340 x 60 mm
T15 boat	ø 10.0 x 4.5 cm, 15 moulds	390 x 340 x 60 mm
T24	ø 4.5 cm, 24 moulds	390 x 340 x 60 mm
T30	ø 4.2 cm, 30 moulds	390 x 340 x 60 mm
T35 square	32 x 32 mm, 35 moulds	390 x 340 x 60 mm
T35 eight angled	32 x 32 mm, 35 moulds	390 x 340 x 60 mm
T46 boat	ø 5.0 x 2.0 cm, 46 moulds	390 x 340 x 60 mm

Capacity: medium



Dimensions (l x w x h) : 490 x 440 x 395 mm

Dimensions (l x w x h) : 19,3 x 17,3 x 15,5 inch

Weight : 32 kg

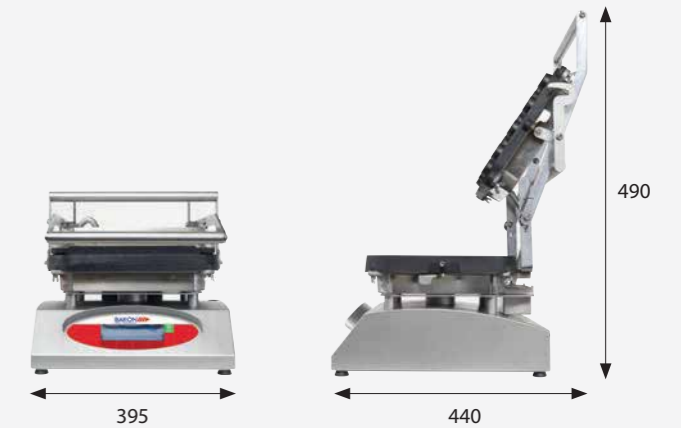

A

The Tartlet Satellite can store max. 45 programs by product name and with separate control of temperature of top and bottom plates and baking time.

B

Digitally adjustable baking time with automatic countdown in seconds and acoustic signal at the end of the baking time.

C



D



E



F

